

HIGH PERFORMANCE
UNIX SUPERMICRO FOR
REAL TIME INDUSTRIAL
AND COMMUNICATION APPLICATIONS

DS90-11



**DATA
INDUSTRIER AB**

UNIX GOES INDUSTRIAL

DS90-11 is a new 16/32 bit UNIX/D-NIX multi-user supermicro from the drawing boards of DIAB, the Swedish innovation company that produced the top-ranked DS90-00. The new DS90-11 is the result of a new design approach which leads to smaller dimensions and higher speed.

SMALL BUT POWERFUL

The DS90-11 is designed for industry and communication applications and comes in two 19" rack units. The CPU unit holds the CPU, the main memory section, a 5 1/4" 640 kbyte floppy disk and backplanes for future expansions. All-metal cabinets, twin cooling fans, over-rated power supplies and a rugged mechanical over all design ensure that the DS90-11 will cope with the tough environment and heavy-duty operation encountered on the plant floor.

Combining high performance with economy, the DS90-11 is a true state-of-the-art machine featuring the powerful Motorola 68010 16/32 bit processor operating at 10 MHz. The standard 2 MByte ECC memory can easily be expanded to 4 MByte. The system supports virtual memory. The DS90-11 has four RS232 ports and expansion to eight or twelve ports is easily done. In fact, a special expansion board allows for even further ports. The standard configuration also offers four DMA channels, two SCSI channels and a VME or DataBoard 4680 bus interface.

The option list covers further RS232 ports, floating point processor, interfaces to intelligent I/O systems, high speed graphics and further mass storage handling.

The memory unit of the DS90-11 contains a 20 - 120 MByte Winchester and an optional 1/4" back-up streamer tape station. Other memories, such as larger disks (SMD) and 1/2" magnetic tapes will also be handled.

D-NIX IS PART OF THE CONCEPT

The D-NIX real time operating system is an in-house DIAB product which is fully compatible with UNIX system V. D-NIX has, however, a number of improvements over the standard UNIX version, for instance better real time performance thanks to a much smaller kernel.

The D-NIX and the DS90-11 thus make a perfect system for any industry application involving real time process control and/or monitoring. The DS90-11/D-NIX combination will also prove to be a development system with almost unlimited potential.

PROVEN DATA COMMUNICATION CAPABILITY

With DIAB's 10 year background in the data communication field, the DS90-11 is the right system in a wide range of communication applications. Of course, the DS90-11 can communicate with other computers. And the DS90-11 can be employed to form the link between other computers, e.g. a gateway from a Univac to an IBM.

Furthermore, communication over LANs and WANs is supported. As are a number of communication protocols such as those given in the specification.

SOFTWARE OFF THE SHELF — TODAY

The DS90-11 comes with the ingenious D-NIX real time operating system (including more than 80 utilities) as standard.

The DS90-11 is a multi-lingual machine and program development may be performed in a vast range of languages.

Software packages available off the shelf are the multi-module MIMER RDBMS, the 4th generation application tool box NECTAR, spreadsheet programs and advanced word processing packages. CP/M and MS-DOS file handlers can also be supplied.

INDUSTRIAL INTEGRATION MADE EASY

The integration capability versus industrial applications have been built into the DS90-11 from the very beginning. The double choice of DataBoard 4680 and VME standard industry interfaces makes it easy to connect the computer for a process control or a data acquisition system.

The DataBoard 4680 is a board computer system numbering some 50 boards for different I/O and interface functions. The VME bus system is supported by several vendors and is steadily growing in extent and popularity.

And, to further facilitate computer integration, a new Industry Quality I/O system is now being launched by DIAB. The new IQ-IO system offers high noise immunity, low cost and exceptional ease of use.

GENERAL SPECIFICATIONS

Unit dimensions: Standard rack mounting, 445 x 385 x 120 mm, (3HE)
Unit weight: CPU Unit 11 kg, Disk unit 13 kg
Operating environment: Less than 35 °C
Line voltage: 220 VAC, 47—440 Hz /115 VAC, 47 - 440 Hz
Disk storage: 20 - 120 MByte
Floppy disk drive: 5 1/4", 640 kbyte/720 kbyte(1,2 Mbyte)
Memory back-up: 1/4" tape streamer

STANDARD SOFTWARE

D-NIX operating system, D-Basic V, Mimer database

OPTIONAL SOFTWARE

Development package: XENIX/UNIX system V.
Programming languages: Validated Fortran 77, C, 68000 Assembler, Cobol, Pascal, Simula, APL, Cross Assembler Z80-8748, Z80 Emulator.
Application software packages: 4th generation application tool box NECTAR, Q-CALC Spreadsheet, LEX68 Word processing. (CP/M and MS-DOS File handlers)

SUPPORTED COMMUNICATION PROTOCOLS

LANs: D-NET, Ethernet with TCP/IP and others. WANs: X25, X21 and others.
IBM3270SNA/BSC, IBM2780/3780 BSC, IBM3770 SNA, Univac UTS4000 and others.

STANDARD HARDWARE

CPU: Motorola 68010
Main memory: 2 MBytes (4 MByte optional)
MMU: No waitstate. Virtual memory (demand paging) supported.
I/O: 4 RS232/V24 ports (8, 12 or more optional). 2 separate buffered SCSI channels. 4 DMA channels (10 Mbits/sec). VME and/or DataBoard 4680 interface.

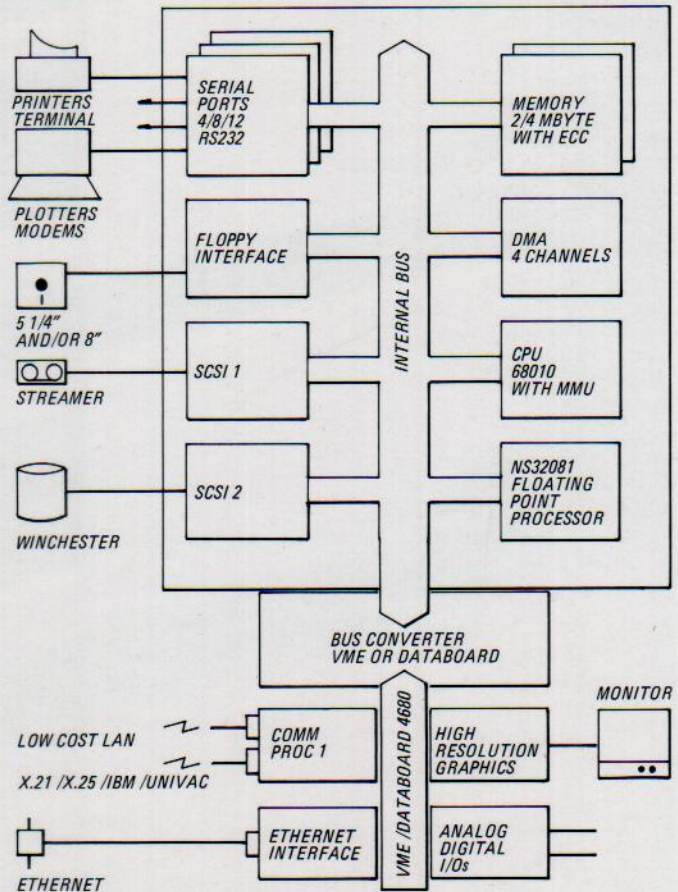

**DATA
INDUSTRIER AB**